

S20LC60US**600V 20A****特長**

- 高耐圧FRD
- 低ノイズ
- $t_{rr}=25\text{ns}$
- θ_{jc} が小さい

Feature

- High Voltage Super FRD
- Low Noise
- $t_{rr}=25\text{ns}$
- Small θ_{jc}

用途

- スイッチング電源
- 家電、OA
- 通信
- フライホール

Main Use

- Switching Regulator
- Home Appliance, Office Automation
- Communication
- Fly Wheel

■外観図 OUTLINE

Package : MTO-3P

Unit:mm

Weight 6.1g(Typ)

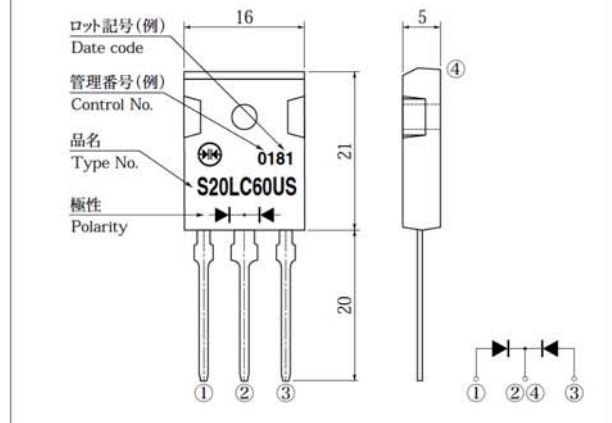

外形図については新電元Webサイトをご参照下さい。捺印表示については捺印仕様をご確認ください。

For details of the outline dimensions, refer to our web site. As for the marking, refer to the specification "Marking, Terminal Connection".

■定格表 RATINGS**●絶対最大定格 Absolute Maximum Ratings (指定のない場合 $T_c = 25^\circ\text{C}$)**

項目 Item	記号 Symbol	条件 Conditions	品名 Type No.	S20LC60US	単位 Unit
保存温度 Storage Temperature	T_{stg}			-55~150	$^\circ\text{C}$
接合部温度 Operation Junction Temperature	T_j			150	$^\circ\text{C}$
せん頭逆電圧 Maximum Reverse Voltage	V_{RM}			600	V
出力電流 Average Rectified Forward Current	I_o	50Hz正弦波, 抵抗負荷, フィン付き, 1素子当りの出力電流平均値 $I_o/2$, $T_c = 63^\circ\text{C}$ 50Hz sine wave, Resistance load, With heatsink, Per diode $I_o/2$, $T_c = 63^\circ\text{C}$		20	A
せん頭サージ順電流 Peak Surge Forward Current	I_{FSM}	50Hz正弦波, 非繰り返し1サイクルせん頭値, 1素子当りの規格値, $T_j = 25^\circ\text{C}$ 50Hz sine wave, Non-repetitive 1 cycle peak value, Per diode, $T_j = 25^\circ\text{C}$		60	A
締め付けトルク Mounting Torque	TOR	(推奨値: $0.5\text{N}\cdot\text{m}$) (Recommended torque: $0.5\text{N}\cdot\text{m}$)		0.8	$\text{N}\cdot\text{m}$

●電氣的・熱的特性 Electrical Characteristics (指定のない場合 $T_c = 25^\circ\text{C}$)

項目 Item	記号 Symbol	条件 Conditions	規格値 Per diode	単位 Unit
順電圧 Forward Voltage	V_F	$I_F = 10\text{A}$, パルス測定, 1素子当りの規格値 Pulse measurement, Per diode	MAX 3.6	V
逆電流 Reverse Current	I_R	$V_R = 600\text{V}$, パルス測定, 1素子当りの規格値 Pulse measurement, Per diode	MAX 50	μA
逆回復時間 Reverse Recovery Time	t_{rr}	$I_F = 0.5\text{A}$, $I_R = 1.0\text{A}$, (回復点90%) (Recovery point 90%)	MAX 25	ns
接合容量 Junction Capacitance	C_j	$f = 1\text{MHz}$, $V_R = 10\text{V}$	TYP 24	pF
熱抵抗 Thermal Resistance	θ_{jc}	接合部・ケース間 Junction to case	MAX 1.0	$^\circ\text{C}/\text{W}$

■特性図 CHARACTERISTIC DIAGRAMS

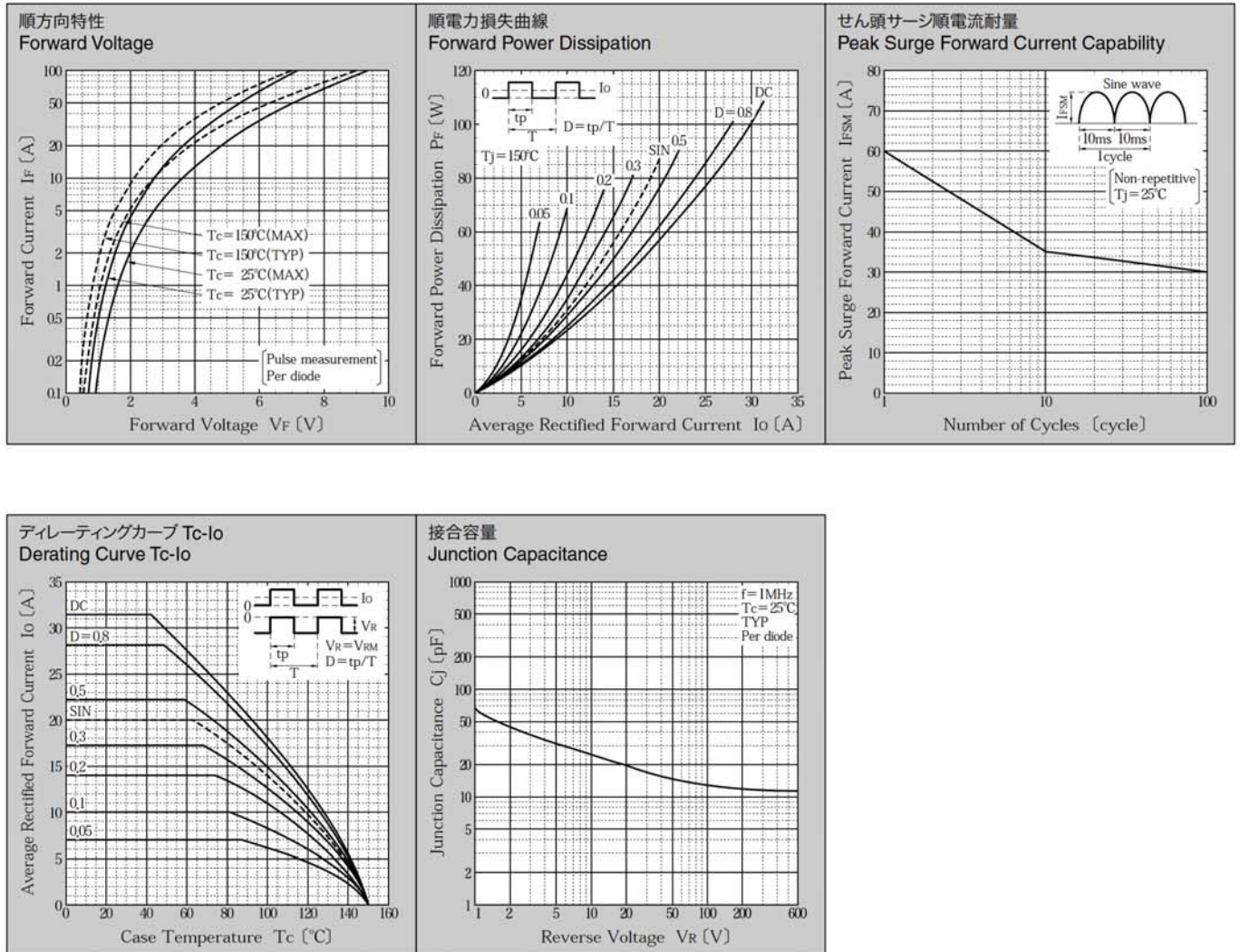

* Sine waveは50Hzで測定しています。
 * 50Hz sine wave is used for measurements.
 * 半導体製品の特性は一般的にバラツキを持っており、Typicalは統計的な実力を表しています。
 * Semiconductor products generally have characteristic variation. Typical is a statistical average of the device's ability.